

## Rolverdichter



Verminderen van het aantal afvalophalingen: Een reductie tot een factor 5.



Gemiddeld containergewicht : < 7ton



Ton Automatische werkcyclus



Automatische as-smering



Instelbare aanslag in beide richtingen

## Voor welke afvalstromen ?



Houten pallets



Houten kistjes



Harde plastics

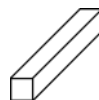

kartonnen kokers

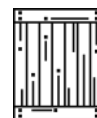

houten kisten



Palletboxen

## Werkingsprincipe

De stationaire rolcompactor is ontworpen om afval en grondstoffen te vermalen en samen te persen, waardoor het aantal transport en kosten aanzienlijk dalen. Een motor drijft een zware rol aan die het afval verplettert en gelijkmatig verdeelt in open containers.



+32 (0) 59 27 08 00



info@altervalbenelux.com

## Rolverdichter

### Gebruiksmethode



Geschikt voor open containers vanaf 30m<sup>3</sup>.  
Minimale lengte : 7m.

### Technische gegevens

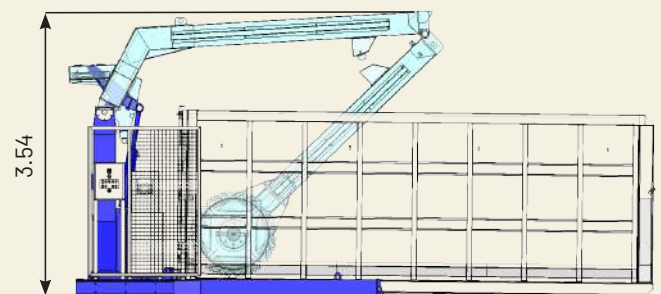
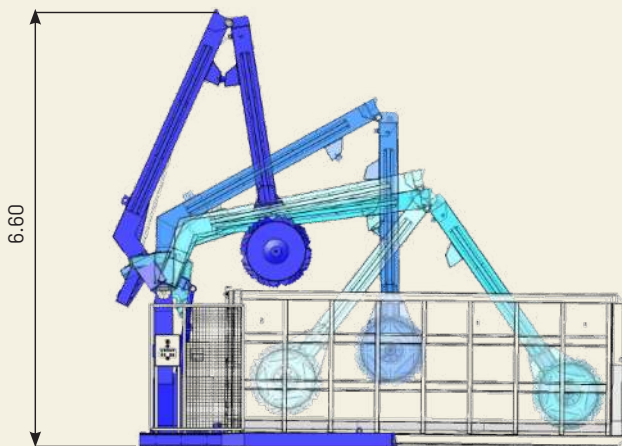

Motorvermogen van 5.5 kW



8.14 X 2.88 X 6.60 m in werking  
Transporthoogte 3.54 m



3750 KG

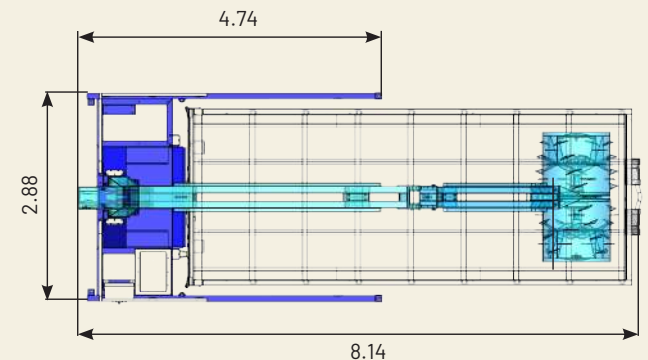

### Resultaten



Met ALTERVAL gaan we een stap verder !

